

1800™ Series Spray Heads Industry's Leading Spray Heads

For over 25 years, 1800 Series Spray Heads have provided unmatched durability, reliability, and performance.

In comparison tests, 1800 Series Spray Heads are 3 times as durable, 2 times as reliable, and #1 in performance – remember 3-2-1*.

Superior components and features make the 1800 the spray head of choice for a wide variety of applications.

Features

- Co-molded, pressure-activated, multi-functional wiper seal assures positive seal without excess “flow-by” which enables more heads to be installed on the same valve.
- Designed for use with all Rain Bird plastic spray head nozzles – U-series, MPR and VAN.
- Precision controlled flush at pop-down clears debris from unit, assuring positive stem retraction in all soil types.
- Strong stainless steel spring provides reliable stem retraction.
- Ratchet mechanism on all models allows easy nozzle pattern alignment without tools.
- Pre-installed 1800 Pop-Top™ flush plug blocks debris from entering after flushing. Allows for easy nozzle installation.
- Constructed of time-proven UV-resistant plastic and corrosion resistant stainless steel parts, assuring long product life.
- All sprinkler components are removable from the top without special tools, providing for quick and easy flushing and maintenance of the sprinkler.
- Side and bottom inlets featured on 1806 and 1812 models.
- Five-year trade warranty.

* Based on tests conducted at Rain Bird's Product Research Center in Tucson, AZ. Test results reflect a comparison with Rain Bird's principal competitors.

Operating Range

- Spacing: 3 to 20 feet (0,9 to 6,1 m)
- Pressure: 15 to 70 psi (1,0 to 4,8 bar)

Specifications

- Flow-by: 0 at 8 psi (0,6 bar) or greater; 0.1 gpm (0,02 m³/h; 0,006 l/s) otherwise

Dimensions/Models

- ½" (15/21) NPT female threaded inlet
- Models and height:
 - 1802: 4" (10 cm) body height; 2" pop-up height (5 cm)
 - 1803: 4⅞" (12 cm) body height; 3" pop-up height (7,6 cm)
 - 1804: 6" (15 cm) body height; 4" pop-up height (10 cm)
 - 1806: 9⅜" (24 cm) body height; 6" pop-up height (15 cm)
 - 1812: 16" (40 cm) body height; 12" pop-up height (30 cm)
- Exposed surface diameter: 2¼" (5,7 cm)

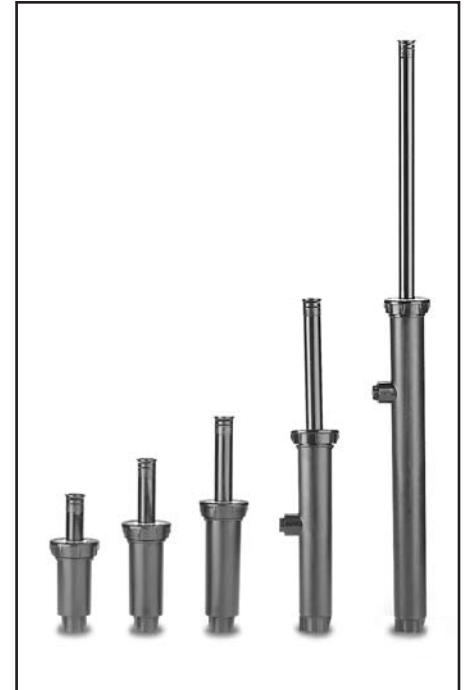

How to Specify/Order

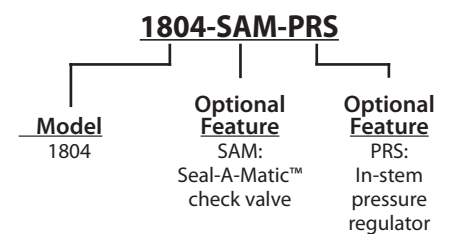



1800™ SAM Series

Ideal for use in areas with changing elevations, the 1800 SAM Series offers all 1800 Series features plus:

- Built-in Seal-A-Matic™ (SAM) check valve. Eliminates the need for under-the-head check valves. No parts to be installed at the site.
- Stronger retract spring to accommodate elevation changes up to 14' (4,2 m). One of the strongest springs in the industry.
- Prevents drainage from spray heads at lower elevations. Stops water waste. Ends landscape damage due to flooding and/or erosion.
- Helps retain water in lateral pipes which reduces wear on system components by minimizing water hammer during start-up.
- Designed for use with all Rain Bird plastic spray head nozzles.
- "SAM" stamped on cap for easy identification and maintenance.
- Five-year trade warranty.

Operating Range

- Spacing: 3 to 20 feet (0,9 to 6,1 m)
- Pressure: 25 to 70 psi (1,7 to 4,8 bar)

Specifications

- SAM capability: holds up to 14 feet (4,2 m) of head; 6 psi (0,3 bar)
- Flow-by: 0 at 8 psi (0,6 bar) or greater; 0.1 gpm (0,02 m³/h; 0,006 l/s) otherwise
- SAM operable only when installed by bottom inlet

Dimensions

- ½" (15/21) NPT female threaded inlets
- Body height: 1804 SAM - 6" (15 cm), 1806 SAM - 9¾" (24 cm), 1812 SAM - 16" (40 cm)
- Exposed surface diameter: 2¼" (5,7 cm)

Models

- 1804 SAM: 4" pop-up height (10 cm)
- 1806 SAM: 6" pop-up height (15 cm)
- 1812 SAM: 12" pop-up height (30 cm)

1800 PRS Series

Designed for areas with high and/or widely fluctuating water pressures, the 1800 PRS Series has all 1800 Series features plus:

- **PATENTED** PRS pressure regulator built into the stem. No parts to be installed at the site. Saves time and money.
- Maintains constant outlet pressure at 30 psi (2,1 bar). Spray heads and nozzles perform best at 30 psi. Ensures maximum spray head and nozzle performance, even with varying inlet pressures. Maintains constant pressure regardless of nozzle used.
- Restricts water loss by up to 70% if nozzle is removed or damaged. Saves water and money. Reduces possibility of accidents and property damage. Recommended for vandal-prone areas.
- Ensures consistent performance throughout zone if nozzle is removed or damaged. Keeps plant life covered by other spray heads properly irrigated.
- Ends misting and fogging caused by high pressure. Stops water waste. Ensures necessary watering occurs in high pressure or wind conditions.
- Designed for use with all Rain Bird plastic spray head nozzles.
- "PRS" stamped on cap for easy identification and maintenance.
- Five-year trade warranty.

Operating Range

- Spacing: 3 to 20 feet (0,9 to 6,1 m)
- Pressure: 15 to 70 psi (1 to 5 bar)

Specifications

- Regulates nozzle pressure to an average 30 psi (2,1 bar) with inlet pressures of up to 70 psi (4,8 bar)
- Flow-by: 0 at 8 psi (0,6 bar) or greater; 0.1 gpm (0,02 m³/h; 0,006 l/s) otherwise
- Installation: side or bottom inlet
- Side inlet installation not recommended in freezing climates

Dimensions

- ½" (15/21) NPT female threaded inlets
- Body height: 1804 PRS - 6" (15 cm), 1806 PRS - 9¾" (24 cm), 1812 PRS - 16" (40 cm)
- Exposed surface diameter: 2¼" (5,7 cm)

Models

- 1804 PRS: 4" pop-up height (10 cm)
- 1806 PRS: 6" pop-up height (15 cm)
- 1812 PRS: 12" pop-up height (30 cm)

1800 SAM-PRS Series

Meets the needs of all spray areas, regardless of changing elevation or water pressures. Incorporates all 1800 Series SAM and PRS features. "SAM-PRS" stamped on the cap for easy identification and maintenance.

Operating Range

- Spacing: 3 to 20 feet (0,9 to 6,1 m)
- Pressure: 25 to 70 psi (1,7 to 4,8 bar)

Specifications

- SAM capability: holds up to 14 feet (4,2 m) of head; 6 psi (0,3 bar)
- Flow-by: 0 at 8 psi (0,6 bar) or greater; 0.50 gpm (0,11 m³/h; 0,03 l/s) otherwise
- SAM operable only when installed by bottom inlet
- Regulates nozzle pressure to an average 30 psi (2,1 bar) with inlet pressures of up to 70 psi (4,8 bar)

Dimensions

- ½" (15/21) NPT female threaded inlets
- Body height: 1804 SAM-PRS - 6" (15 cm), 1806 SAM-PRS - 9¾" (24 cm), 1812 SAM-PRS - 16" (40 cm)
- Exposed diameter: 2¼" (5,7 cm)

Models

- 1804 SAM-PRS: 4" pop-up height (10 cm)
- 1806 SAM-PRS: 6" pop-up height (15 cm)
- 1812 SAM-PRS: 12" pop-up height (30 cm)

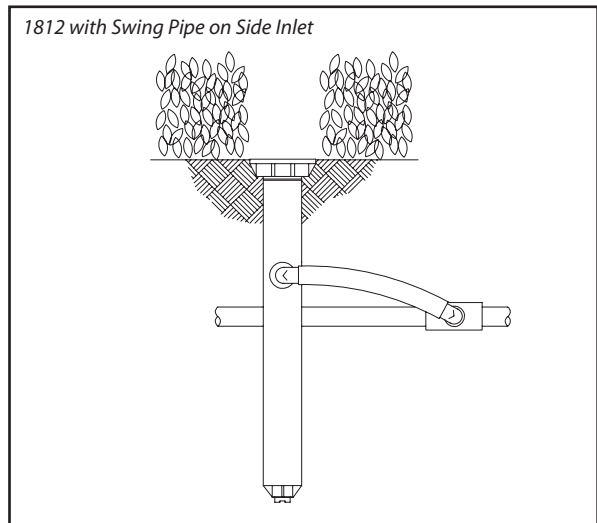
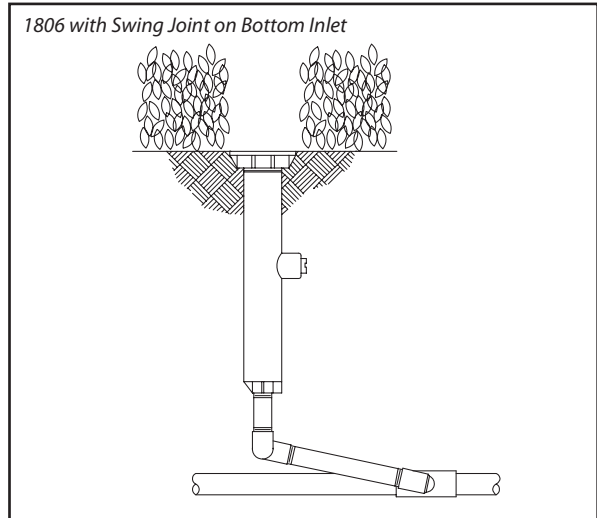
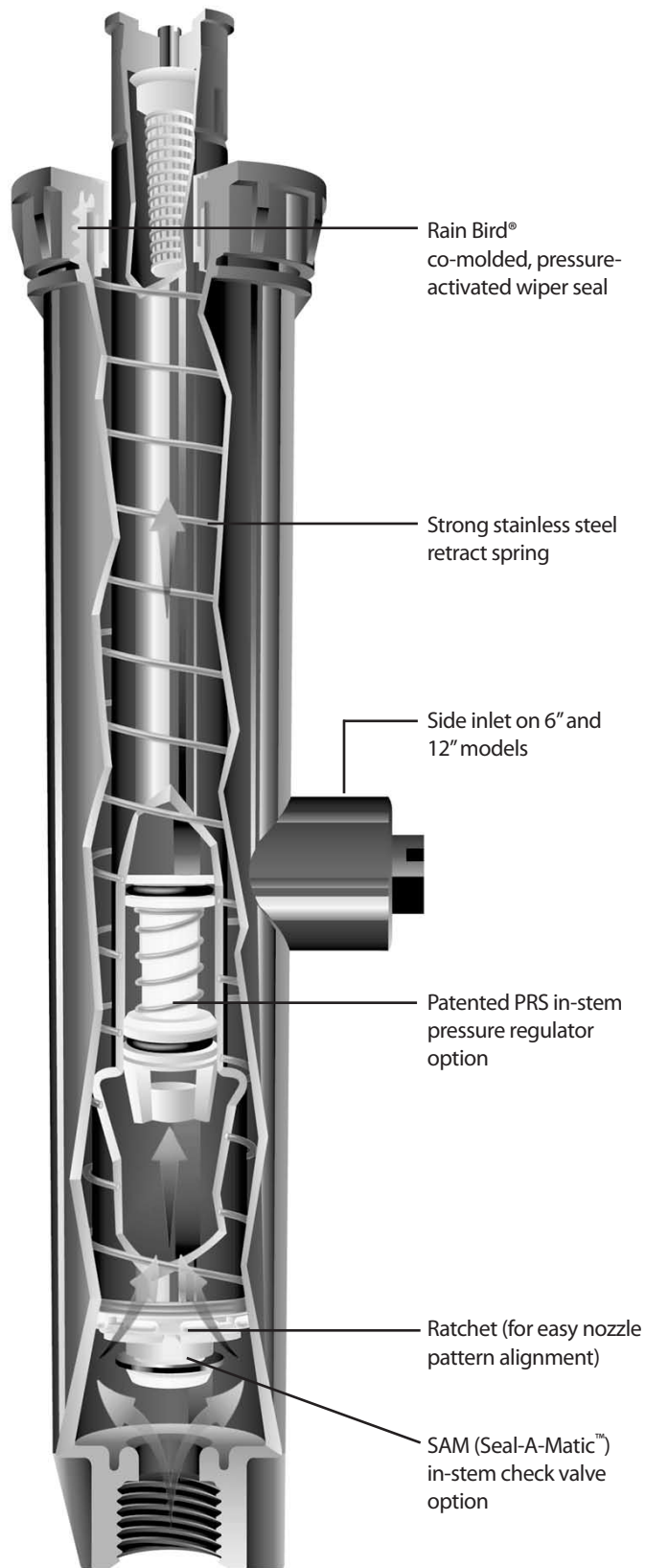



Specifications

1802, 1803, 1804, 1806 and 1812 Pop-up Full or Part Circle Spray Sprinkler

The sprinkler body, stem, nozzle and screen shall be constructed of heavy-duty, ultra-violet resistant plastic. It shall have a heavy-duty stainless steel retract spring for positive pop-down and a ratcheting system for easy alignment of the pattern. The sprinkler shall have a soft elastomer pressure-activated co-molded wiper seal for cleaning debris from the pop-up stem as it retracts into the case to prevent the sprinkler from sticking up to minimize "flow-by."

The sprinkler shall have a matched precipitation rate (MPR) plastic or brass nozzle with an adjusting screw capable of regulating the radius and flow. The sprinkler shall be capable of housing protective, non-clogging filter screens or pressure compensating screens (PCS) under the nozzle. The screen shall be used in conjunction with the adjusting screw for regulating. The 6" (15 cm) and 12" (30 cm) models shall have both a side and a bottom 1/2" (15/21) (FNPT) inlet for ease of installation.

The sprinkler shall have a Pop-Top™ Flush Plug pre-installed. The plug shall prevent debris from clogging the sprinkler during installation and allow for the system to be flushed before nozzling. The plug shall be bright orange in color and constructed of polypropylene material.

1804 SAM, 1806 SAM and 1812 SAM Full or Part Circle Seal-A-Matic™ Pop-up Spray Sprinkler

Optional Feature Specifications:

When so indicated on the design, the 4", 6" or 12" high pop-up spray sprinklers shall also include a Seal-A-Matic (SAM) check valve to prevent low-head drainage of up to 14 feet of head. This feature shall require the use of the bottom inlet only. These units shall be identifiable from the top with "SAM" marking on the cap. The sealing device shall be an integral part of the pop-up stem, removable through the top of the sprinkler, and shall seal against the bottom case inlet. It shall create no more than 1 psi pressure drop at the maximum rated flow.

1804 PRS, 1806 PRS and 1812 PRS Full or Part Circle Pressure Regulating Pop-up Spray Sprinkler

Optional Feature Specifications:

When so indicated on the design, the 4", 6" or 12" high pop-up spray sprinkler shall also include a pressure regulating (PRS) device to prevent high pressure fogging to the nozzle stream. This regulating device shall be an integral part of the pop-up stem, removable through the top of the case. These units shall be identifiable from the top with "PRS" markings on the cap.

The device shall regulate the nozzle pressure to 30 psi for inlet pressures from 35 to 70 psi. Below 35 psi the pressure loss shall not exceed 6 psi.

1804 SAM-PRS, 1806 SAM-PRS and 1812 SAM-PRS Seal-A-Matic Pressure Regulating Pop-up Spray Sprinkler

Optional Feature Specifications:

When so indicated on the design, the 4", 6" or 12" high pop-up spray sprinkler shall also include a Seal-A-Matic (SAM) check valve and a pressure regulating (PRS) device. These units shall be identifiable from the top with "SAM-PRS" markings on the cap.

The check valve shall prevent low-head drainage of up to 14 feet of head. The pressure regulating device shall prevent high pressure fogging of the nozzle stream by regulating the nozzle pressure to 30 psi for inlet pressures from 35 to 70 psi. Below 35 psi the pressure loss shall not exceed 6 psi. These models shall utilize the bottom inlet only.

The sprinkler shall be as manufactured by Rain Bird Corporation, Azusa, California.

Rain Bird Corporation

6991 E. Southpoint Road, Tucson, AZ, 85706, U.S.A.
Phone: (520) 741-6100 Fax: (520) 741-6522

Rain Bird Corporation

970 W. Sierra Madre Avenue, Azusa, CA, 91702, U.S.A.
Phone: (626) 812-3400 Fax: (626) 812-3411

Rain Bird International, Inc.

P.O. Box 37, Glendora, CA, 91740-0037, U.S.A.
Phone: (626) 963-9311 Fax: (626) 852-7343

Technical Service and Support

(800) RAINBIRD (U.S. and Canada only)

Specification Hotline

(800) 458-3005 (U.S. and Canada only)

www.rainbird.com

The Intelligent Use of Water™ — Visit www.rainbird.com to learn about our efforts